

Viper Select Gallonage (SG) Series

Select Gallonage: Four settings @ 100 PSI & Flush

Swivel NST or NPSH except on 2 1/2"

Weights: 3.4lbs(1560), 4.3lbs(3012/7515), 6.5lbs(9520)
7.3lbs(9520-2 1/2"/12250)

Lengths: 7.87"(1560), 8.85"(3012/7515), 11.2"(9520),
12.8"9520-2 1/2"/12250)

Made of extruded E-Lite alloy & Hard anodized

All Viper models are individually tested

(Low Pressure also available on most models)

SG9520



SG1560



SG9520-2 1/2"



SG3012



SG12250



SG7515



QUALITY AFFORDABLE PRODUCTS

3842 Redman Dr. Fort Collins CO 80524

Phone: 888-663-4966 - Fax:970-663-4966 - www.cssupplyinc.com

MODEL	NOZZLE PRESSURE (psi)	NOZZLE FLOW (gpm)	STREAM SETTING	EFFECTIVE REACH
SG1560	75	13	SS	59
		26	SS	82
		43	SS	92
		52	SS	102
	100	15	SS	62
		30	SS	85
		50	SS	98
		60	SS	108
	125	17	SS	69
		34	SS	98
		56	SS	105
		67	SS	108
SG3012	75	26	SS	75
		52	SS	105
		82	SS	125
		108	SS	131
	100	30	SS	85
		60	SS	112
		95	SS	131
		125	SS	141
	125	34	SS	92
		67	SS	118
		106	SS	138
		140	SS	148
SG7515	75	65	SS	112
		87	SS	121
		108	SS	135
		130	SS	138
	100	75	SS	118
		100	SS	138
		125	SS	114
		150	SS	148
	125	84	SS	125
		112	SS	141
		140	SS	151
		168	SS	157
SG9520	75	82	SS	121
		108	SS	131
		130	SS	141
		173	SS	144
	100	95	SS	128
		125	SS	141
		150	SS	148
		200	SS	154
	125	106	SS	128
		140	SS	141
		168	SS	144
		224	SS	161
SG12250	75	94	SS	125
		113	SS	135
		150	SS	144
		188	SS	148
	100	125	SS	131
		150	SS	144
		200	SS	151
		250	SS	157
	125	140	SS	135
		168	SS	144
		224	SS	154
		280	SS	164

VIPER SG9520/12250



SG9520 AND SG12250 BOM			
REFERENCE	PART NAME	PART #	QUANTITY
A	SPINDLE SET PIN	V-SETPIN-9520	1
B	SPINDLE HEAD	V-SPNDLHD-9520	1
C	RET. RING SET PIN	V-SETPIN-RR-9520	2
D	RETAINER RING	V-RTNRRNG-9520	1
E	SPINNING TEETH	V-TEETH-9520	1
F	OUTER BARREL	V-OUTRBRRL-9520	1
G	BUMPER	V- BUMPER-9520	1
H	OUTER BARREL SET PIN	V-SETPIN-OB-9520	1
I	INNER BARREL O-RING 1	V-ORING-IBL-9520	1
J	INNER BARREL	V-INNERBARREL-9520	1
K	INNER BARREL O-RING 2	V-ORING-IBS-9520	1
L	SELECTOR SET PIN	V-SETPIN-SLCT-9520	1
M	FLOW REGULATOR	V-FLOWREG-9520	1
N	CLICK CYLINDER	V-CLKCYL-9520	1
O	CLICK SPRING	V-CLKSPRING-3012	1
P	BUSHING	V-BSHING-9520	1
Q	NOZZLE BARREL	V-NZLBARREL-9520	1
R	NOZZLE BARREL O-RING	V-ORING-9520	1
S	SPINDLE SHAFT	V-SPNDLSHFT-9520	1
T			
U			
V	FLOW REG. GUIDE	V-FLREGGUIDE-9520	1
W	BEARING SET PIN	V-SETPIN-9520	1
X	BALL BEARINGS	V-BEARINGS-3012	32

SG9520/12250 TIP

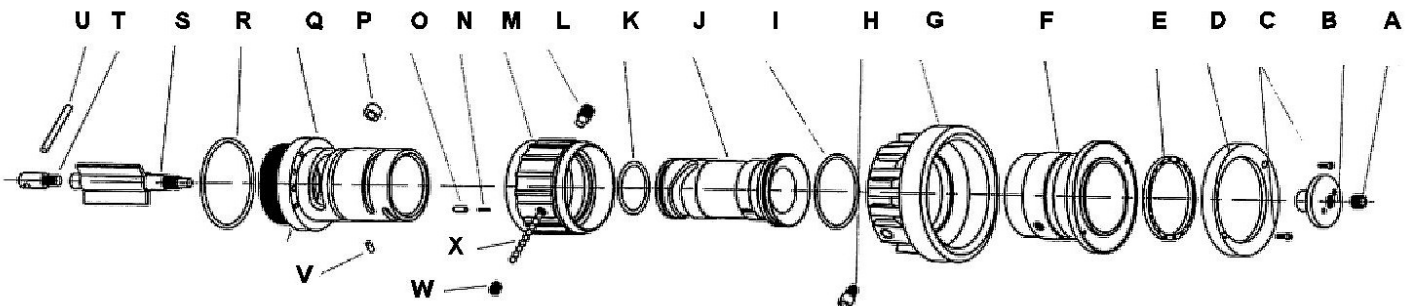

CS Supply
QUALITY AFFORDABLE PRODUCTS

3842 Redman Dr. Fort Collins CO 80524
 Phone: 888-663-4966 - Fax: 970-663-4966 - www.cssupplyinc.com

VB9520 and VB9520-2.5 BOM (VALVE)			
REFERENCE	PART NAME	PART #	QUANTITY
1	1.5" GASKET	GASKET_15	1
1a	2.5" GASKET	GASKET_25	1
2	1.5" SWIVEL (LARGE)	V-1.5" SWIVEL-9520	1
2a	2.5" SWIVEL	V-2.5" SWIVEL-9520	1
3	SWIVEL O-RING	V-ORING-SW-9520	1
4	BALL	V-BALL-9520	1
5	PISTOL GRIP	V-PG15V	1
6	BALL LOCATOR (2 PIECES)	V-BALLOCAL-9520	1
7			
8	PISTOL GRIP SET PIN	V-SETPIN-PG	1
9	VALVE BODY	VLVBDY-9520	1
10	SEAT RETAINER (3 PIECES)	V-SEATRTNR-9520	1
11			
12			
13	BALL ACTUATOR (2 PEICES)	V-BALLACT-9520	1
14			
15	PAN HEAD COVER	V-PANHEAD-9520	1
16	SWIVEL SET PIN	V-SETPIN-9520	1
17	BALL BEARINGS	V-BEARINGS-9520	32
18	HANDLE (BAIL)	V-HANDLE-9520	1

VB9520 and VB9520-2.5 AVAILABLE KITS		
KIT#	KIT Name	PARTS CONTAINED
VNRK-9520	VIPER NOZZLE REPAIR KIT SG9520 OR SG12250	A,B,C,D,E,G,H,I,K,L,N,O,P,R,S,T,U,V,W,X 1,1a,3,4,5,6,7,8,10,11,12,13,14,15,16,17,18
VVRK-9520 (*)	Valve Repair Kit Lg.	1,1a,3,4,6,7,10,11,12,13,14,15,16,17,18
VBSC-9520	Ball & Seat Combo Lg.	4,10,11,12
V-HH5-9520	Handle Hardware Lg.	6,7,13,14,15
V-SWKIT9520	Swivel Kit 1" Lg.	1,3,16,17
V-SWKIT9520-2.5	Swivel Kit 1.5" Lg.	1a,3,16,17

DANGER

**PLEASE BE RESPONSIBLE!
PLEASE BE CAREFUL!**

THE USER OF THIS EQUIPMENT IS PERSONALLY RESPONSIBLE FOR THE FOLLOWING:

1. You need to know and understand that Fire-fighting and Emergency response is dangerous and proper training is needed.
2. You need to be physically fit and skillful in the use of any equipment that you may need to use.
3. You need to know that your equipment is in proper working order.
4. You need to know carelessness or negligence may result in injury or death.

**PLEASE BE RESPONSIBLE!
PLEASE BE CAREFUL!**

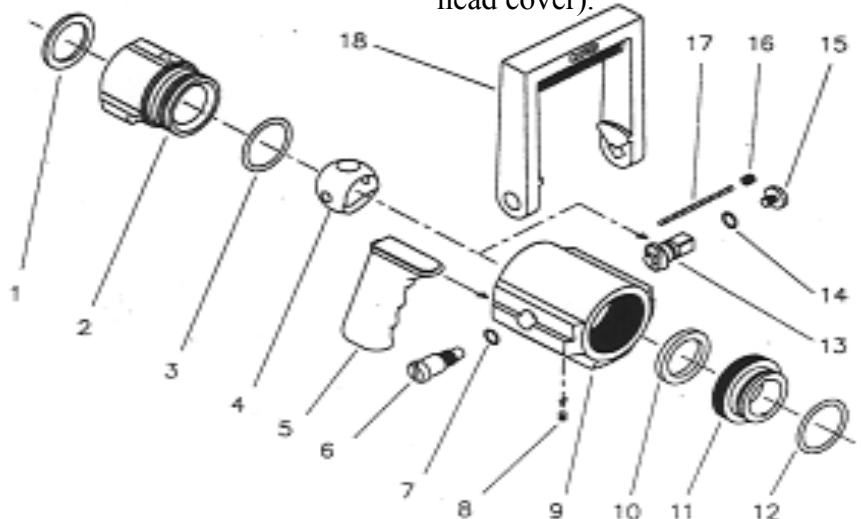

SHUTOFF USE:

- Open and close the valve slowly to reduce risk of water hammer.
- Pull the bail handle toward the swivel to OPEN the valve.
- Push the bail handle toward the tip of the nozzle to CLOSE the valve.

TIP USE:

- The Gallonage selector ring indicates the flow in gallons per minute at 100 psi.
- Flush setting is made to discharge obstructions from the nozzle while flowing water.
- Rotate the rubber bumper on the end to select spray pattern.

Maintenance:

- Test nozzle before putting into service.
- Clean nozzle by flushing with water after use.
- Use non-detergent soap to clean dirt from the exterior to reduce wear.
- Regularly check the bail handle screws that they are tight. If taken out use medium thread locker on the threads before reassembly.
- Periodically service your nozzle or have your fire equipment dealer service it.
- Normally serviced parts are the: Ball, Seat assembly, Spinning teeth, and the handle hardware (Ball locator screw, Actuator, Pan head cover).